

MA STER 30

CNC WORK CENTRES
FOR GLASS



 **INTERMAC**

THE PERFECT SOLUTION FOR BIG COMPANIES AND SMALL WORKSHOPS

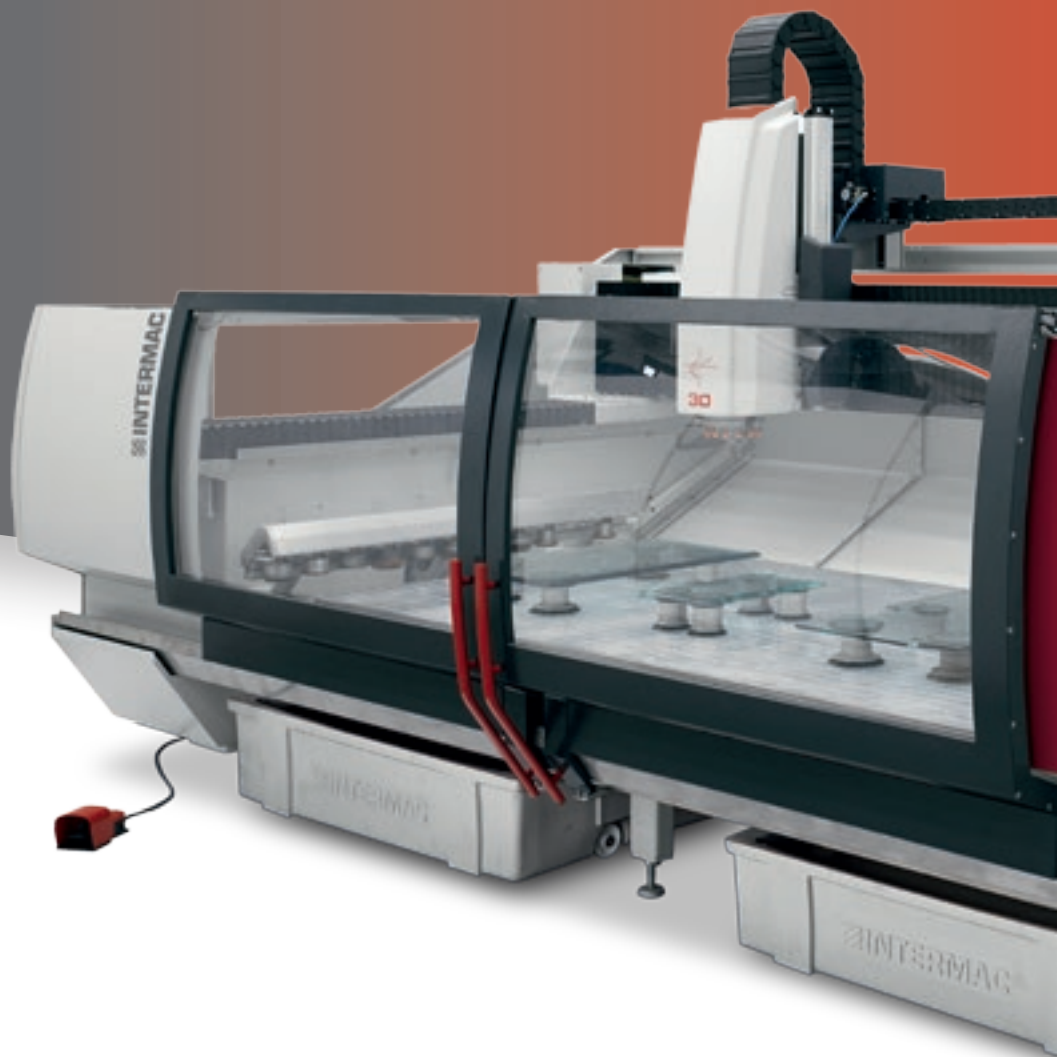

THE MARKET CALLS FOR

a change in production processes to meet the ever growing request for personalised products that satisfy customers' specific needs.

This is coupled with the need to maintain high quality standards whilst offering product customisation with quick and defined delivery times.

INTERMAC RESPONDS

with manufacturing technologies that enhance and support technical abilities and knowledge of processes and materials. **Master 30** is the machining centre dedicated to glass processing, aimed at companies that require high production rates, as well as small entrepreneurs who wish to automate their production processes. Thanks to the work table, which spans over three metres, the Master 30 offers the same degree of robustness, precision and speed that characterises the most powerful machines currently on the market.



MASTER 30

- ▣ **ROBUST AND FAST.**
- ▣ **HIGH TECHNOLOGY WITH A MODEST INVESTMENT.**
- ▣ **MAXIMUM FINISH QUALITY.**
- ▣ **PRECISION AND RELIABILITY DURING ALL MACHINING OPERATIONS.**
- ▣ **EXCELLENT PRODUCTION EFFICIENCY THANKS TO THE PERFECT INTEGRATION WITH ROBOTS FOR THE PRODUCTION OF LARGE BATCHES.**

VERSATILITY AND FLEXIBILITY THANKS TO THE WIDE VARIETY OF POSSIBLE MACHINING OPERATIONS



Milling.



Grinding and peripheral finishing.

3-axis machining guarantees optimum reliability and precision when creating doors, bathroom unit tops, shower enclosures or glass for household appliances and the automotive and electronic sectors.

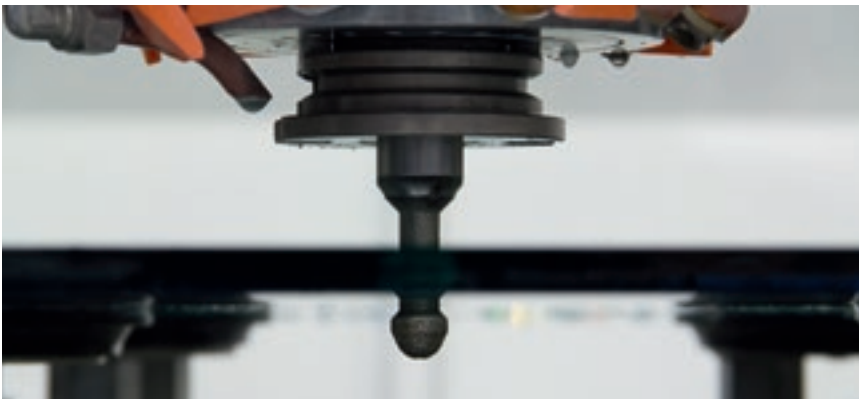

Boring integrated with the Helix system.



Boring from above.



Surface writing.

Master 30 can manage long, complex machining operations and also shorter ones for mass production, ensuring optimum results in both cases.

REVOLUTIONARY BORING

Helix is the Diamut tool that, when combined with Intermac software, exceeds all the limits of the traditional boring systems, using one single tool for all the boring, grinding and countersinking operations on glass sheets of up to 19mm.

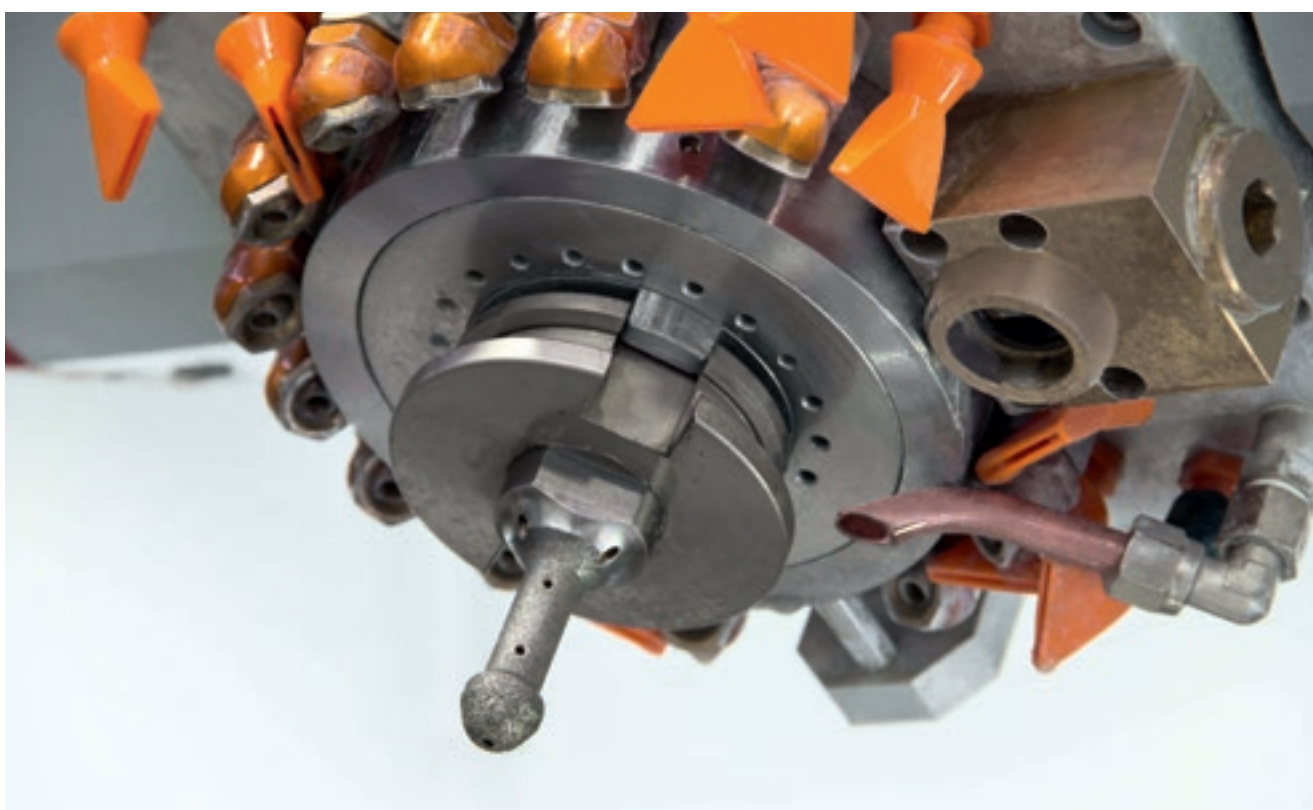

DEVELOPED, PATENTED QUALITY

Innovation created by a team of Diamut and Intermac experts, Helix System is the perfect blend of hardware and software that emerges in the whole range of Master processing centres.

The new standard for boring operations.

Helix System was born of the desire to develop a revolutionary boring system unlike anything that has been seen on the market to date, capable of drilling holes with integrated upper and lower counter-sink on glass sheets up to 19mm thick, using a single tool on CNC machines.

INTEGRATED BORING SYSTEM

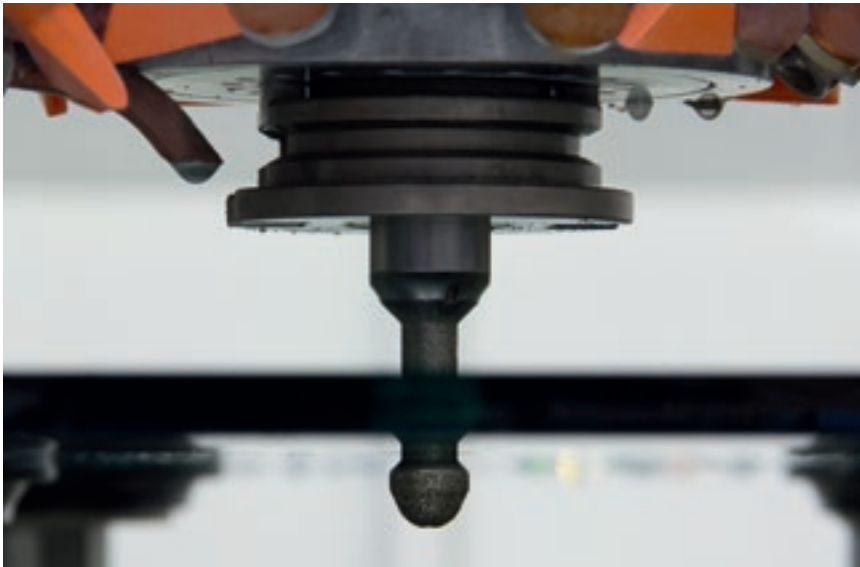

An innovative tool, managed by specific software.

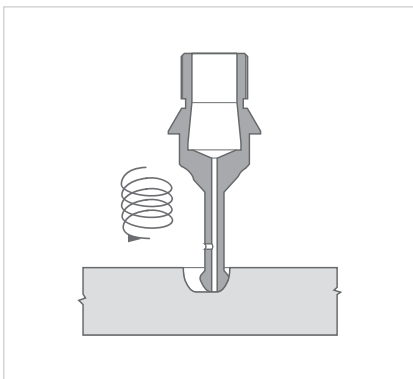

1_Boring with helical movement

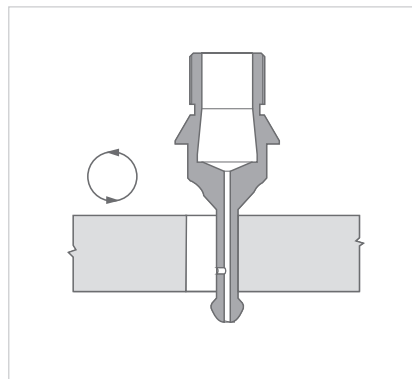

2_Lateral grinding

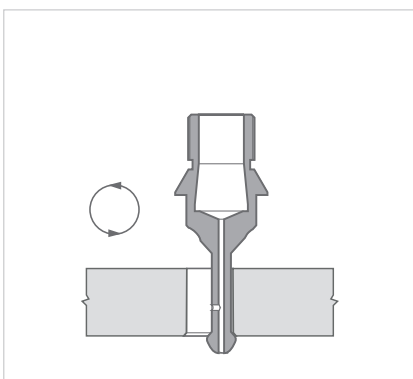

3_Lower countersinking

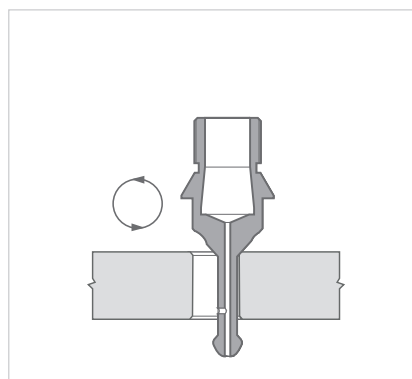

4_Upper countersinking

- ▣ Maximum finish quality.
- ▣ Machining tolerances are halved.
- ▣ Holes with different diameters, with just one tool.
- ▣ Can also be used on laminated glass.
- ▣ Integrated upper and lower countersinking.
- ▣ Machining operations on any part of the sheet.
- ▣ Tool cleaning blow after the machining operation.

MAXIMUM MACHINING RELIABILITY AND PRECISION



The Master range is fitted with spindles manufactured by HSD - a world leader in its sector. They guarantee optimum power, compact dimensions and extremely high finishing standards.

- ▀ **+60% of spindle life with reduced noise**
thanks to 4 ceramic bearings that ensure increased resistance to mechanical stress.
- ▀ **Greater reliability**
thanks to the use of stainless steel and the 55mm spindle shaft.



DPC (patented) - Controlled loss distributor

A patented system that ensures excellent reliability and a long lifespan, thanks to the innovative seal system with no mechanical contact.

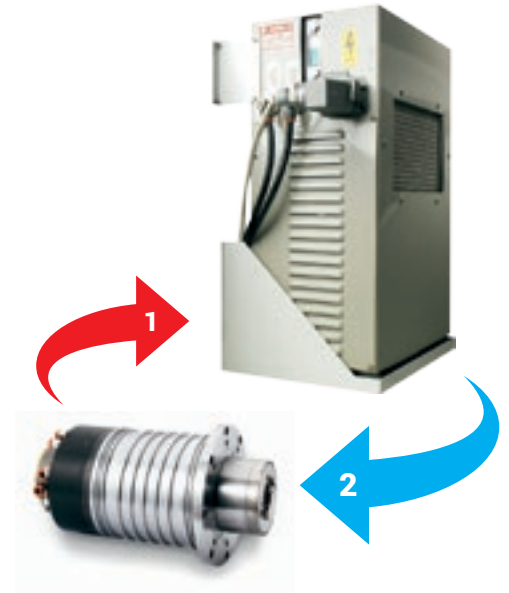

Optional **glycol-based cooling** systems with a closed circuit that guarantees constant results over time and resistance to the maximum machining stress levels.

- 1. High-temperature fluid**
(cooling system with heat exchanger).
- 2. Low-temperature fluid**



Master 30 is equipped with an integrated system for the automatic greasing of the movement axes, ensuring constant and precise maintenance every day.

The machine work table is an extremely rigid structure upon which is placed an aluminium worktable calibrated to grant maximum flatness of the work area, fundamental for first class machining results. The machine is designed to work in twin-station mode too.

The beam is moved by an electronic gantry to ensure greater accuracy and a longer lifespan.



FAST, PRECISE TOOLING



UP TO 24 TOOLS

12-position (standard) side tool change with casing for protection against machining residues for the cones, plus automatic tool loading via the working unit.

The machine can also be equipped with a second 12-position tool magazine.

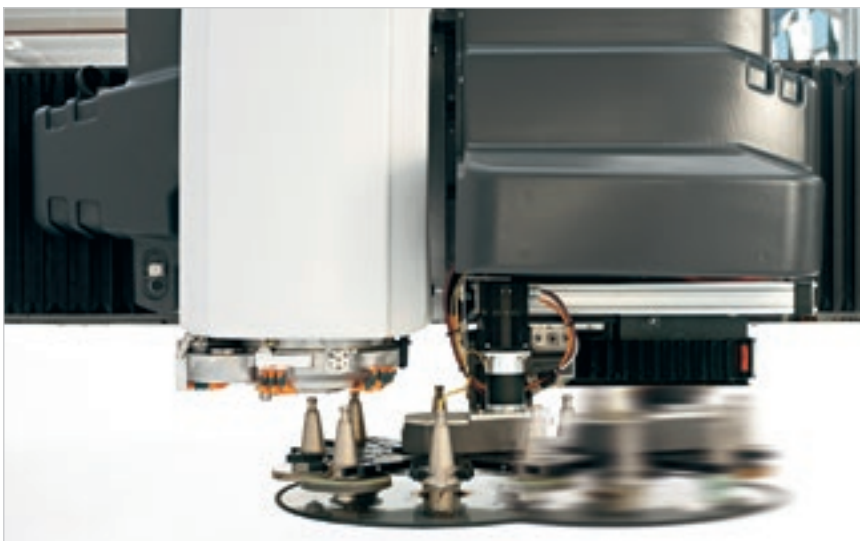

Tool change in 10 second

The fastest solution in the world of glass, thanks to the 8-position revolver magazine on the head.

MACHINING QUALITY AND SPEED

Maximum results, thanks to the possibility to equip the machine with a series of optional elements using top quality components.



Master 30 can be fitted with the mechanical pre-setter which has a fully automatic system that quickly and simply ensures highly accurate and updated tool measurements during the machining processes, thereby avoiding any risk of error on the part of the operator.



Pressure intensifier for the external water

This is a circular wheel with small nozzles that increase the pressure of the external water. This optional device has a 3-position vertical movement to ensure that the water impact point is always the best one, regardless of the tool radius and height.

GLASS THICKNESS	STD SPEED	INCREASE
4mm	18m/min	+40% (up to 25m/min)
10mm	2.5m/min	+60% (up to 4m/min)
19mm	1.8m/min	+66% (up to 3m/min)



Quick piece locking system with vacuum, using the double pedal fitted on the machine as standard.

The optional dressing devices are positioned near the working area for fast, easy tool dressing operations that guarantee constant top quality and speedy execution. The dressing function renders the Master 30 fully automatic, including during longer machining operations, whilst simplifying manual operations.

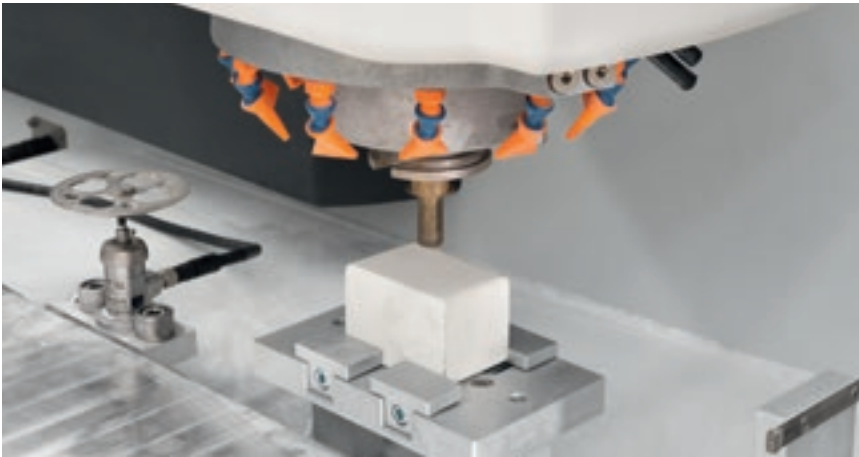

Drill dressing.



Finishing wheel dressing.



Diamond wheel dressing.

EFFICIENT PRODUCTION, WITH NO LIMITS

The Master range can be perfectly integrated in a line with robots and loading/unloading systems. It's the ideal solution for those who need automated solutions for producing large batches (the household appliance field and the automotive, electronic and furnishing sectors).



MASTER 30 increases productivity and reduces production costs thanks to:

- ▶ **The possibility to work with twin stations,** with piece loading and unloading while the machine is running.
- ▶ **Reduced work time for the operator**
- ▶ **Simplification of the work for the operator,** who only needs to manage the racks at the start and end of the machining batch.
- ▶ **Machining operations that require no supervision and have no time limits (24/7)**

INDUSTRY 4.0 READY

Industry 4.0 is the latest industry frontier, based on digital technologies and machines that speak to the companies. The products can be interconnected with the production processes via smart networks.



Intermac's commitment is to transform our customers' factories with real-time technology, ready to guarantee digital manufacturing opportunities, with smart machines and software packages becoming vital tools that facilitate the daily tasks of people all over the world processing glass, stone, metal and more. Our philosophy is a practical one: to supply entrepreneurs with solid data that can help them to lower their costs, optimise their processes and improve their results.

And that means being 4.0 ready.

ICAM: THE MOST SIMPLE ANSWER

WITH OVER 6,500 PACKAGES INSTALLED AND USED BY SATISFIED CUSTOMERS IN 180 COUNTRIES THROUGHOUT THE WORLD, ICAM IS A HIGHLY RELIABLE AND ROBUST SOFTWARE THAT COMBINES TOP PERFORMANCE WITH EXTREMELY EASY USE.

▸ **Ease of use**

A simple, powerful interface for working quickly and easily.

▸ **Time savings**

Positioning of stops and suction cups within the CAD/CAM environment, minimising tooling times even when the project is subject to modifications.

▸ **Innovative**

A unified interface for the CAD and CAM environments.

▸ **Automated**

The parametric library and "Indoor" module allow machining operations to be generated quickly and automatically in accordance with the item being created.

▸ **Service quality**

The expertise of the Service Worldwide network.

DESIGNED TO MEET THE REAL PROGRAMMING NEEDS OF MASTER WORKING CENTRES, WITH THE AIM OF MAKING THE JOB QUICKER AND EASIER. SOLUTIONS BASED ON THE STANDARDS BUT FOCUSED ON THE FUTURE.



PROTECTION AND SAFETY FOR ALL MACHINING OPERATIONS

Intermac has always paid the utmost attention to the health and safety of its customers. The protection of every operator during the use of the machine is of vital importance, preventing any possible distraction or error that could lead to inconvenience or even accidents.

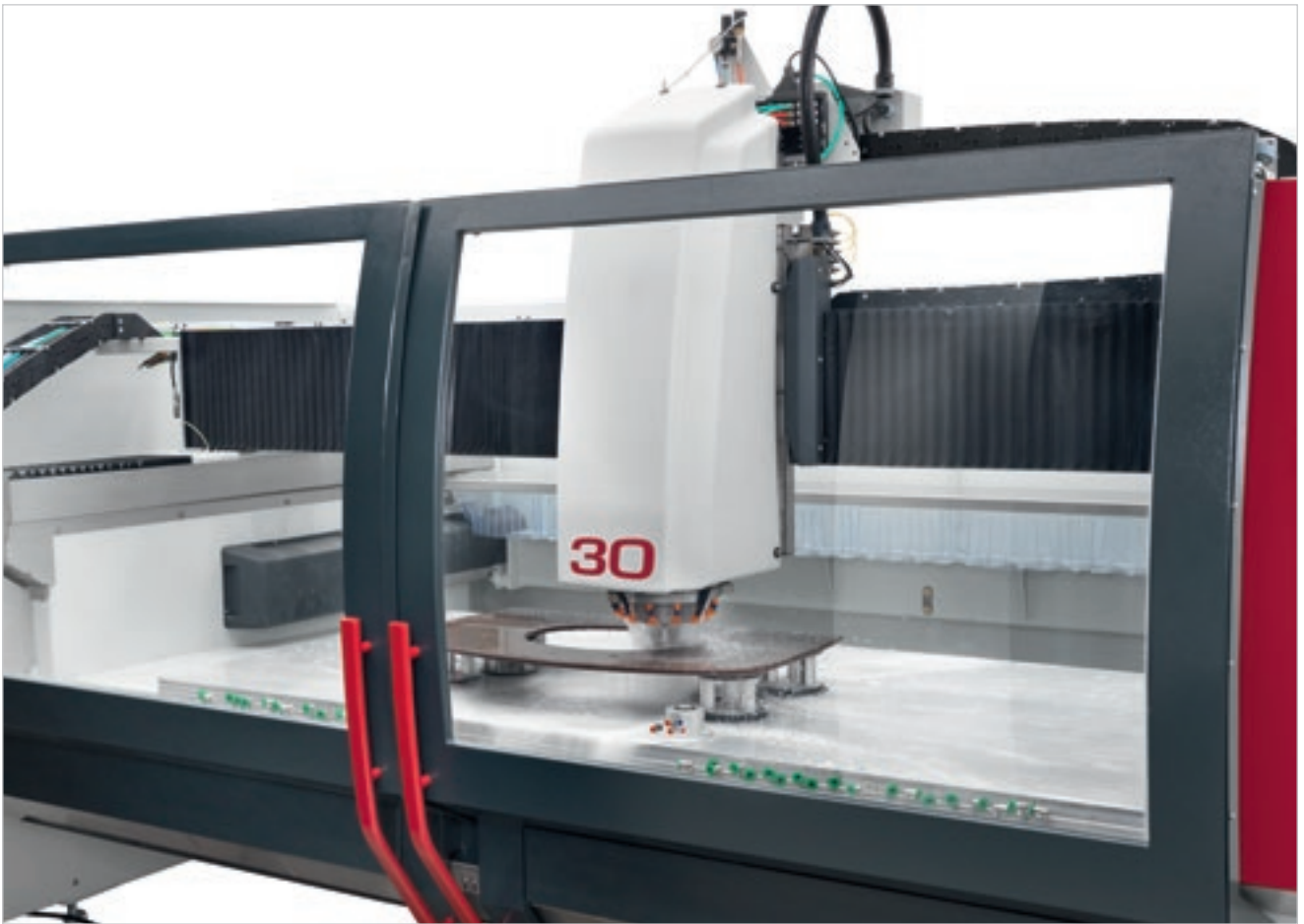

One indispensable condition for obtaining any sort of financing is the respect of the machinery directives and workplace health and safety regulations.

With Master working centres, the operator is protected by:

- Ergonomic front guards of a suitable height that are also explosion-proof (certified by external bodies with "detonation" tests).
- Side and rear guards made of a metallic material subjected to special anti-corrosion painting cycles.
- Electric and pneumatic systems fully integrated in the machine and protected by closed doors.
- Inaccessibility of moving machine parts.
- A clean working environment (water and machining residues are not dispersed).
- Reduced noise levels, fully complying with the machinery directive.



Optimum convenience in the operations thanks to a hand-held terminal with:

- ▀ Quick, simplified positioning of the stops and suction cups thanks in part to the option of tooling the work table with doors open.
- ▀ Simplified tool preparation, thanks to the optimum control of the working head directly on the piece to be machined, and no limits between operator and Master.
- ▀ Machining speed control.
- ▀ Emergency button always near the operator's hand.
- ▀ Start buttons for the two machining stations.
- ▀ A machining pause and restart button.



Extremely easy to use, thanks to the ergonomic console and user-friendly operator interface.

The use of a PC with the Windows operating system, along with a touch-screen display, makes it easy and intuitive for the operator.

SERV ICE & PARTS

Direct, immediate coordination of service requests between Service and Parts. Support for key customers from specific Intermac personnel, in-house and/or at the customer's site.

INTERMAC SERVICE

- ▣ Machine and line installation and start-up.
- ▣ Training centre for Intermac field technicians and subsidiary/dealer personnel; customer training directly at the customer's site.
- ▣ Overhaul, upgrade, repairs and maintenance.
- ▣ Remote diagnostics and troubleshooting.
- ▣ Software upgrade.

85

Intermac field technicians in Italy and worldwide.

20

Intermac technicians working in Teleservice Centre.

35

certified dealer technicians.

50

training courses in a variety of languages every year.



SERVICE TEAM

The Biesse Group promotes, cares and develops direct and constructive relationships with the customers to meet their needs, improve after-sales products and services through two dedicated areas: Intermac Service and Intermac Parts. With its global network and highly specialised team, the company offers on-site and on-line assistance and spare parts for machines and components anywhere in the world, 24/7.

INTERMAC PARTS

- Original Intermac spare parts and spare parts kits customised to suit the machine model.
- Spare part identification support.
- Offices of DHL, UPS and GLS couriers located within the Intermac spare parts warehouse, with multiple daily pick-ups.
- Optimised order dispatch time, thanks to a global distribution network with de-localised, automated warehouses.

95%
of machine downtime orders dispatched within 24 hours.

95%
of orders dispatched on time.

30
spare parts staff in Italy and worldwide.

150
orders processed every day.

TECHNICAL DATA

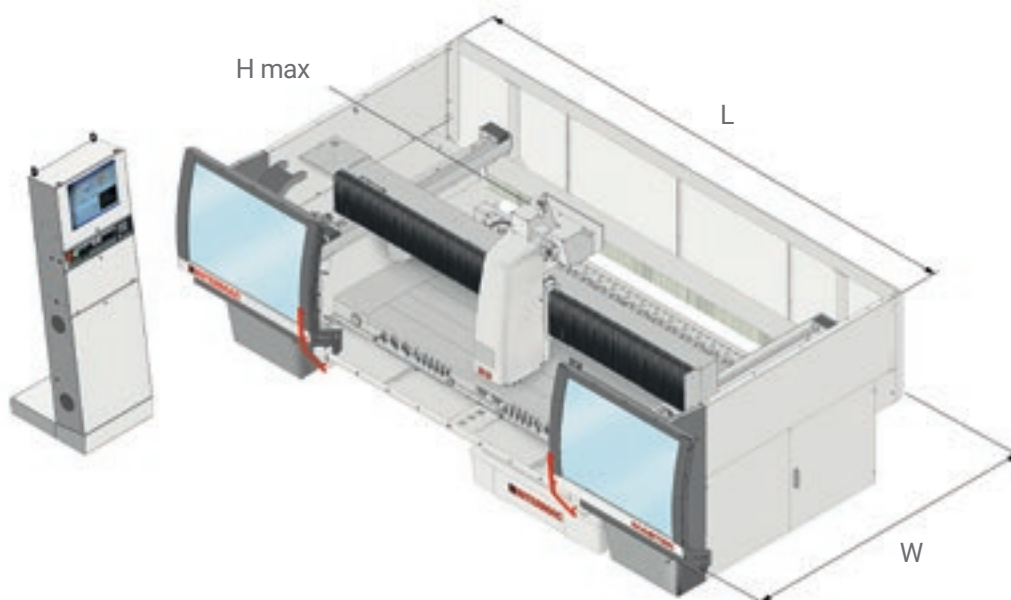

MASTER 30

Maximum piece size for machining with a 100m grinding wheel (peripheral grinding)	mm	3000x1620
Z axis stroke	mm	390
Overall machine dimensions	mm	L: 6880 (doors open) L: 5970 (doors closed) W: 3270 H: 3150
Max axis speed (X - Y - Z)	m/min	60 - 30 -15
Work table height	mm	730
Electrospindle power	kW	7.5
Max electrospindle rotation	rpm	12000
Tool coupling		ISO 40
Maximum tool diameter	mm	150
Standard tool magazine	positions	12
Lateral tool magazine (optional)	positions	12
Tool magazine on head (optional)	positions	8
Working air pressure	bar	7
Max air consumption	NI/min	160
Internal water consumption	l/min	10.5

COMPLETE RANGE OF SOLUTIONS FOR GLASS

TABLES FOR FLOAT GLASS CUTTING



Genius RS-A

Genius CT-A series

Genius CT-RED series

LAMINATED GLASS CUTTING BENCHES



Genius LM series

Genius LM-A series

MACHINES FOR CUTTING LAMINATED AND FLOAT GLASS



Genius Comby Lines

LINES FOR CUTTING FLOAT OR LAMINATED GLASS



Genius Lines & Systems

WATER JET CUTTING SYSTEMS



Primus 184

Primus series

MACHINES AND SYSTEMS FOR DOUBLE-EDGING GRINDING



Busetti F series

Busetti P series

Soluzioni su misura

MACHINING CENTRES



Master 23

Master 30

Master 33.3-38.3-45.3

Master 33.5-38.5-45.5-45.5Plus

SPECIAL PROCESSING CENTRES AND AUTOMATIC CELLS



Master 63-65

Master 95

Master 185

SPECIAL PROCESSING CENTRES AND AUTOMATIC CELLS



Master con cinghie

PROCESSING CENTRES FOR GROOVING OPERATIONS



Master 34

VERTICAL MACHINES



Vertmax series

V-Loader

MADE WITH ZYTRONIC

THE UNMISTAKABLE FINGERPRINT OF THE CNC MASTER

Zytronic, a company that produces tactile technology and touchscreen solutions, opts for the sophisticated technology of Intermac machining centres to guarantee the highest level user experience. When using a touchscreen or any device to purchase a train ticket, make a withdrawal from an ATM, purchase a soft drink or play at a slot machine, response time is the factor that determines user satisfaction for the interaction with the electronic device. That's why Zytronic develops innovative, patented tactile solutions that have made it the leader in touchscreen solutions for the past 15 years. To serve such a wide-ranging market the company needs to develop great flexibility in the production of various screen types, and Intermac has, over

time, proven to be the perfect supplier for technology that guarantees quality, precision and impeccable finishing. Zytronic and Intermac boast a historic relationship based on mutual trust and respect, and the company already owns two Intermac machines: a Master 33 and a superb Compact Edge, which have proven to be the ideal choice for guaranteed quality and reliability over time. Production Director Adrian Leyland explains: "We need to be able to offer unique products for our customers, guaranteeing the highest level user experience with regard to the interaction with touch technology. In addition, the size of touchscreens is increasing, with shapes becoming more and more complex; this is precisely why the flexibility that the Master 23 guarantees when

machining glass into the shapes that we want is absolutely fundamental." All of these factors led us to choose Intermac once again. The decision has bolstered Zytronic's market success, which was already strong thanks to years of experience in the glass machining sector. Sales and Marketing Director, Ian Crosby, adds: "We keep receiving more and more requests from our customers for frameless touchscreens, and once again the Master 23 helps us find the right solution and outdo the competition. Thanks to Intermac, we are sure to win the challenge of providing the utmost user experience".



THE GRO UP

IN

1 industrial group,
4 business sectors
and 9 manufacturing sites

HOW

14 mln €/year in R&D
and 200 patents filed

WHERE

37 branch offices
and 300 agents
and select partners

WITH

customers in 120 countries:
manufacturers of furniture, design
items and door/window frames,
producers of elements for the
building, nautical and aerospace
industries

WE

3800 employees worldwide



 **BIESSE**GROUP

 **BIESSE**

 **INTERMAC**

 **DIAMUT**

MECHATRONICS

